



FOYOT

知识产权声明:
本设计的结构和技术参数的知识产权归:
浙江数娱电子科技有限公司所有, 在未经
本公司书面许可, 不得复制或仿制。
如经发现被复制或仿制将受到法律的严惩。

因改良等原因, 规格以及外观有所变更时, 不再另行通知, 敬请谅解。
Without further notice if specification and exterior have been
changed because of improvement thanks for your understanding

组合件型号: FY-CRJ-95-F&FY46ZM-D75
建议工件重量为8.5kg以下使用

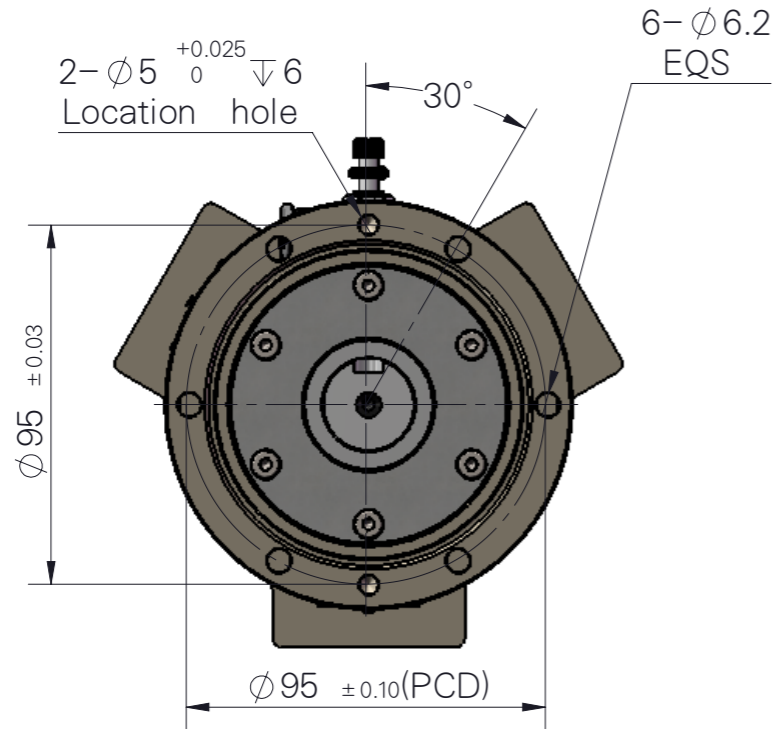

产品名称: 无限连续旋转接头-D95
型号: FY-CRJ-95-F

输入方式: 电动或气动
最高使用转速不大于: 130转/分钟
最高使用扭矩: 22N.m
使用气压范围: 0.2~1.5MPa
组合件整体重量: 2.8kg
所安装的夹爪建议使用: FOYOT品牌

警告:

- 1.当操作夹爪工作时, 请人员务必远离夹爪和机器人的活动部位, 否则将会造成人身伤害的险;
- 2.由于不同物件有其不同的摩擦系数, 当初次夹持工件时, 请在空旷场地进行试夹, 确保夹稳固后方可装机工作, 否则将会有跌落工件砸伤机器或人员的风险

Warning:

- 1.When operating the gripper, please keep away from it Gripper and robot's moving parts, otherwise it will Risk of personal injury;
- 2. Because different objects have different friction coefficients, When clamping the workpiece for the first time, please try clamping in an open field. Ensure that the clamping is firm before the machine can work, otherwise it will There is a risk that falling workpieces may damage machines or personnel.

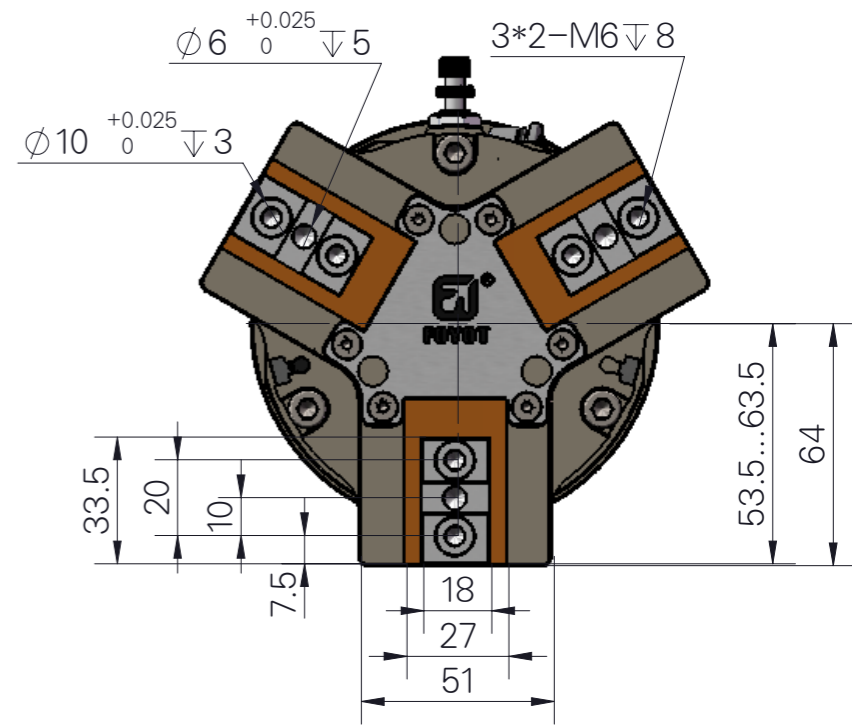
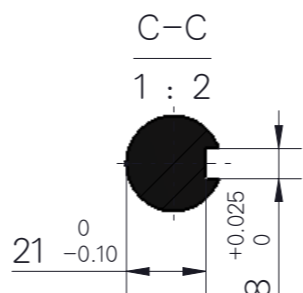
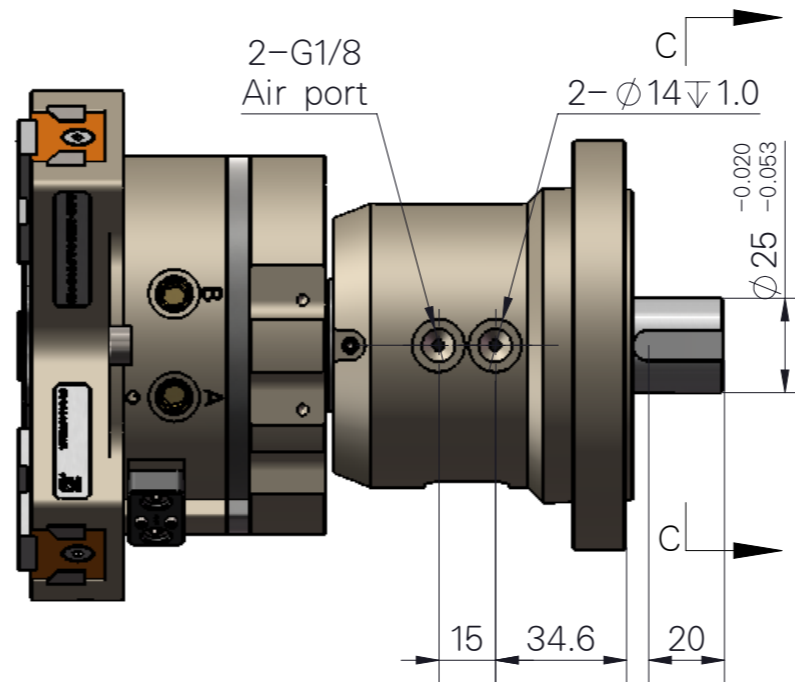
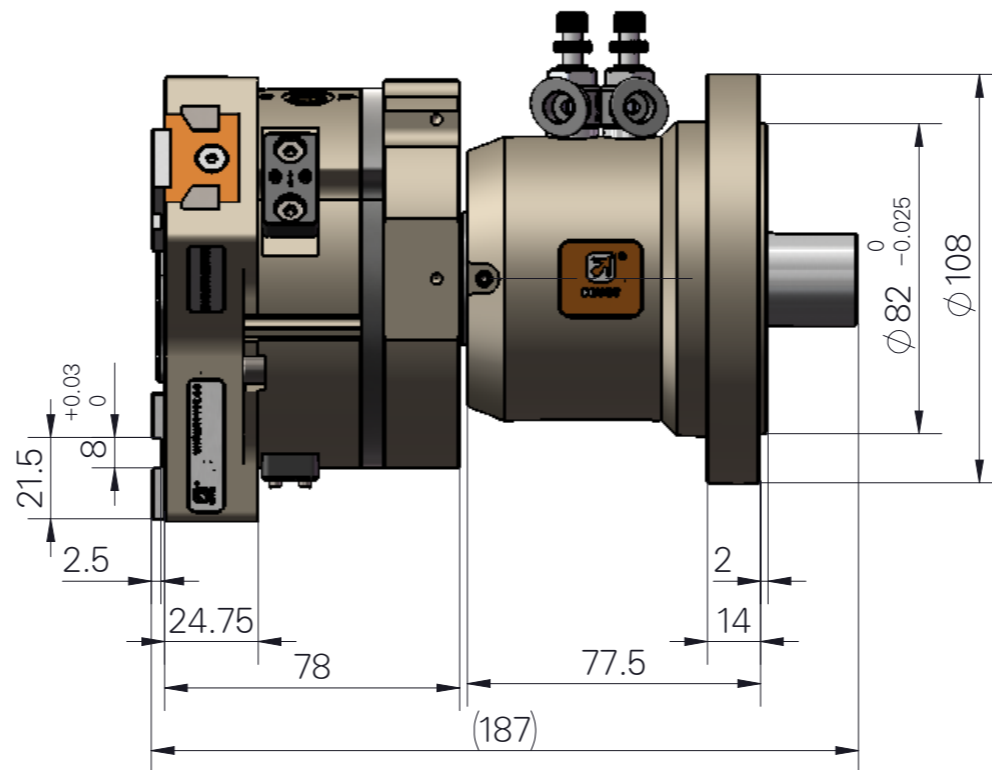

名称: 气动平行三爪
Name: Pneumatic parallel three claws
型号 (Model) : FY46ZM-D75
P:空气压力 (bar) P:Air Pressure(bar)
L:到作用点距离 (mm) L:Exertion Length(mm)
开闭范围 (Stoke) :20mm
仅夹爪产品重量 (Weight):1.65kg
最大附件长度 (Max. length attach):100mm
配管接口 (Fitting size):PF (G)1/8
理论夹持力-开 (Gripping force :Open):2952.8N
理论夹持力-闭 (Gripping force : Close):2822.3N
单循环空气消耗量 (Air consumption per cycle):103.6cm³
开闭时间 (Closing/Opening time):0.10/0.10sec
重复精度 Repeat accuracy):0.02mm
连续使用次数 (Continuation usage amount):40
使用气压 (Operating pressure):3~8bar
周围温度 (Ambient temperature):-5 to 60°C (-10 to 130°C)
润滑 (Lubrication):不需要 (Needless)
根据 IEC60529 标准安全防护:IP64
Safety protection according to IEC60529 standard:IP64
所有数据在 7 Bar 时测量 (All data were measured at 7 Bar)
重复精度: 连续动作100次以后的检测值
After 100 consecutive strokes to end positions